



# Greifarme | Saugfinger

Saugfinger für Vakuumsauger – starr

## Saugfinger für Vakuumsauger – starr



### Produktbeschreibung

- > Elemente zur Montage von Vakuumsaugern
- > Alternativer Vakuumanschluss am Schaftende

### Technische Daten

Art.-Nr.	Gewicht [g]	Abmessungen							
		∅ A [mm]	F	G	H	∅ B [mm]	E [mm]	C [mm]	L [mm]
GR03.001A	11	10	M5	--	--	12	13	45,5	30
GR03.002A	16	10	M5	--	--	12	13	75	60
GR03.003A	22	10	M5	--	--	12	13	105	90
GR03.010A	27	14	G1/8	--	--	16	20	67,5	45
GR03.011A	39	14	G1/8	--	--	16	20	112,5	90
GR03.012A	49	14	G1/8	--	--	16	20	152,5	130
GR03.036	64	20	G1/4	G1/8	G1/8	22	23	75,5	50
GR03.037	100	20	G1/4	G1/8	G1/8	22	23	125	100
GR03.038	137	20	G1/4	G1/8	G1/8	22	23	175,5	150
GR03.039	203	30	G1/4	--	G1/4	30	30	230	200

### Abmessungen

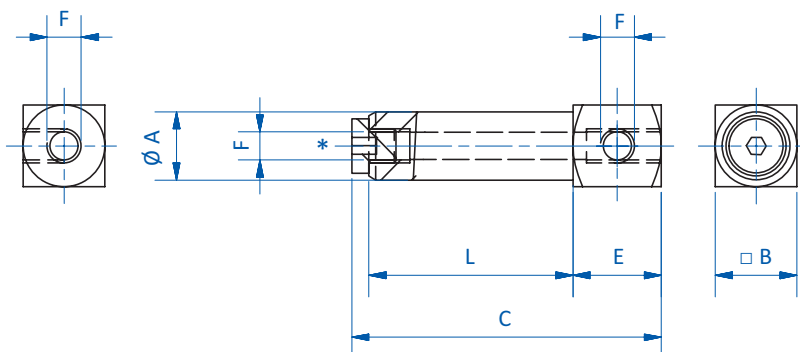

GR03.001A | GR03.002A | GR03.003A | GR03.010A | GR03.011A | GR03.012A

\* = alternativer Vakuumanschluss



Abmessungen

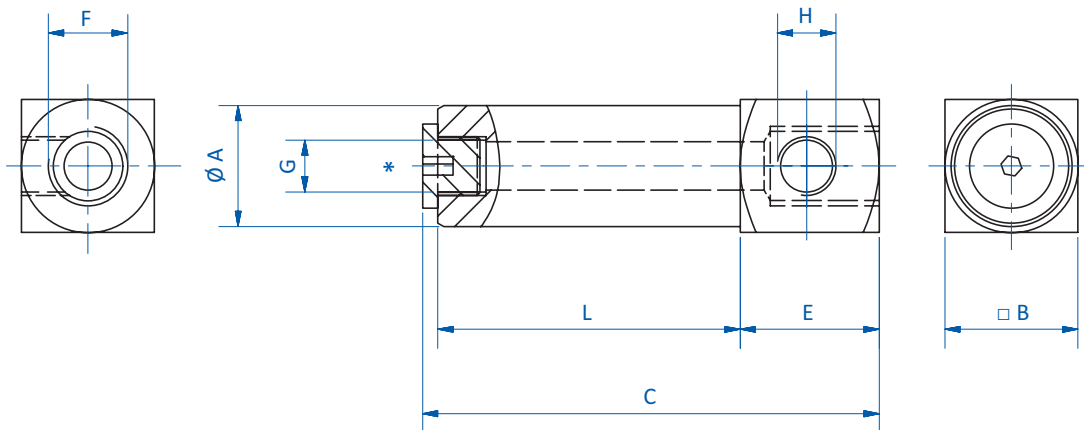

GR03.036 | GR03.037 | GR03.038

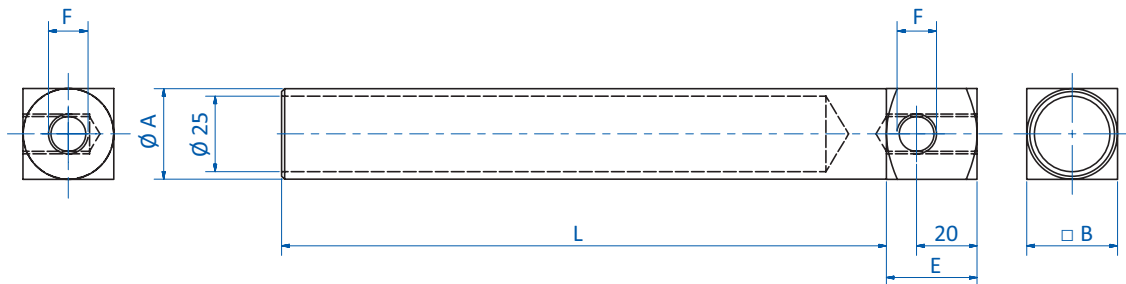

GR03.039

\* = alternativer Vakuumanschluss